

General Description

Series 6F flow control valves provide precise control of flow and shut-off in one direction, and automatically permit full flow in the opposite direction.

Operation

A two-step needle allows fine adjustment at low flow by using the first three turns of the adjusting knob. The next three turns open the valve to full flow, and also provide standard throttling adjustments.

Features

- Meets ISO 6149 standards.
- Hard metric dimensions.
- Reliable leak-free performance — straight thread port with o-ring sealing.
- Global interchangeability.

Specifications

Maximum Operating Pressure	M16 x 1.5	345 Bar	(5000 PSI)
	M18 x 1.5	345 Bar	(5000 PSI)
	M22 x 1.5	345 Bar	(5000 PSI)
	M27 x 2.0	207 Bar	(3000 PSI)
	M33 x 2.0	207 Bar	(3000 PSI)
Maximum Flow	M16 x 1.5	19 LPM	(5 GPM)
	M18 x 1.5	30 LPM	(8 GPM)
	M22 x 1.5	57 LPM	(15 GPM)
	M27 x 2.0	95 LPM	(25 GPM)
	M33 x 2.0	151 LPM	(40 GPM)
Material	Body	ASTM 12L14	Carbon Steel
	Knob	ASTM 12L14	Carbon Steel
	Needle	ASTM 416	Stainless Steel
	Poppet	ASTM 416	Stainless Steel
	Retainer	ASTM 416	Stainless Steel
	Spring	ASTM 316	Stainless Steel
Temperature Range of Seal Compound	-40°C to +121°C (-40°F to +250°F) Nitrile (Standard)		
	-26°C to +205°C (-15°F to +400°F) Fluorocarbon		

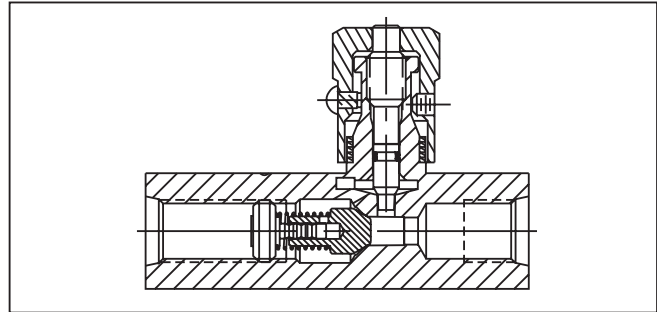
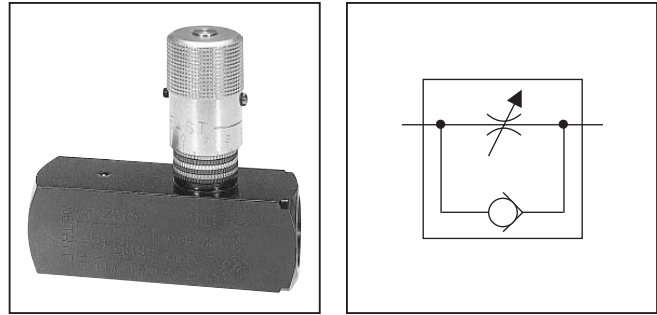

Performance Curves

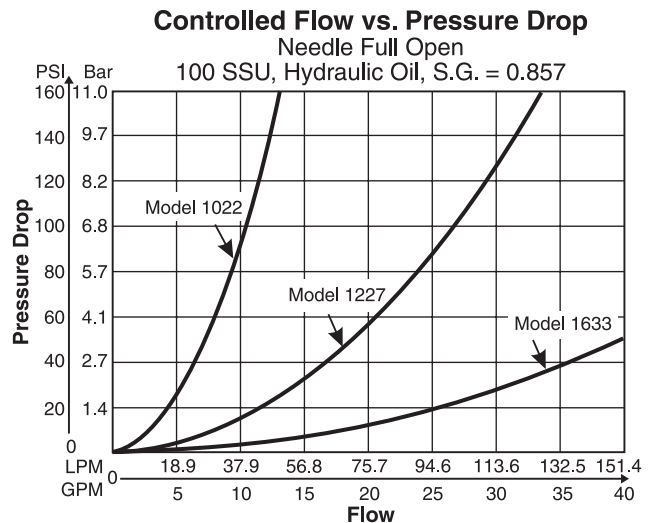
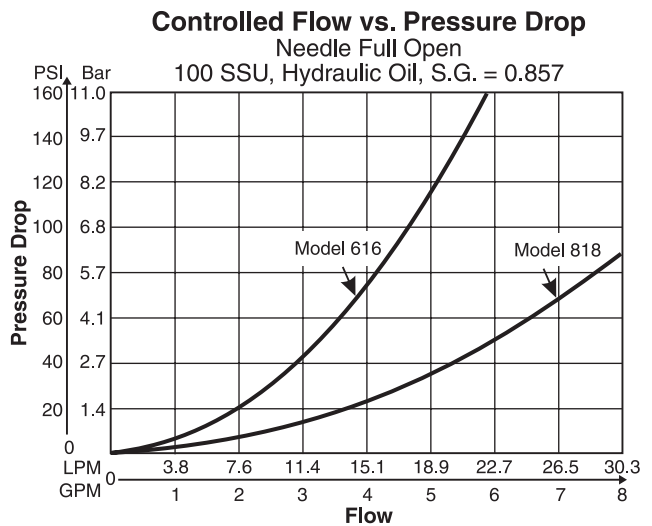

Ordering Information

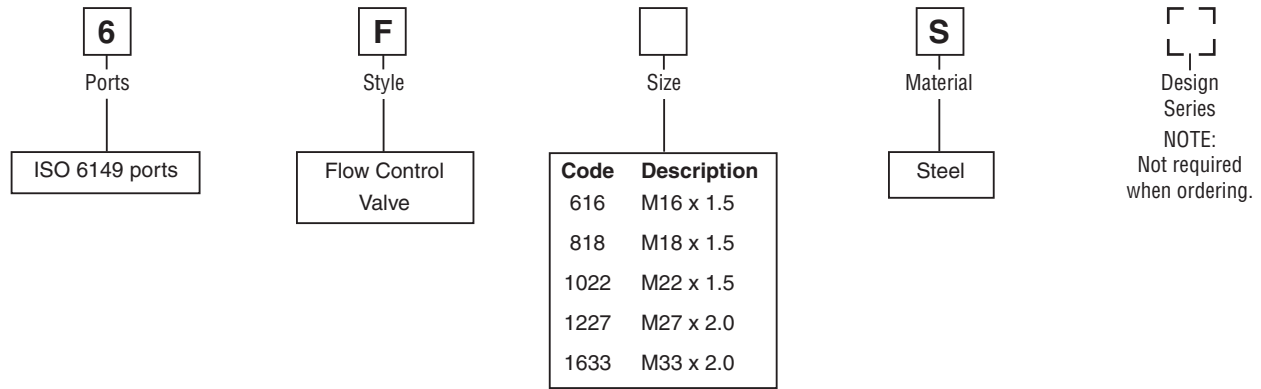

Dimensions

Inch equivalents for millimeter dimensions are shown in (**)

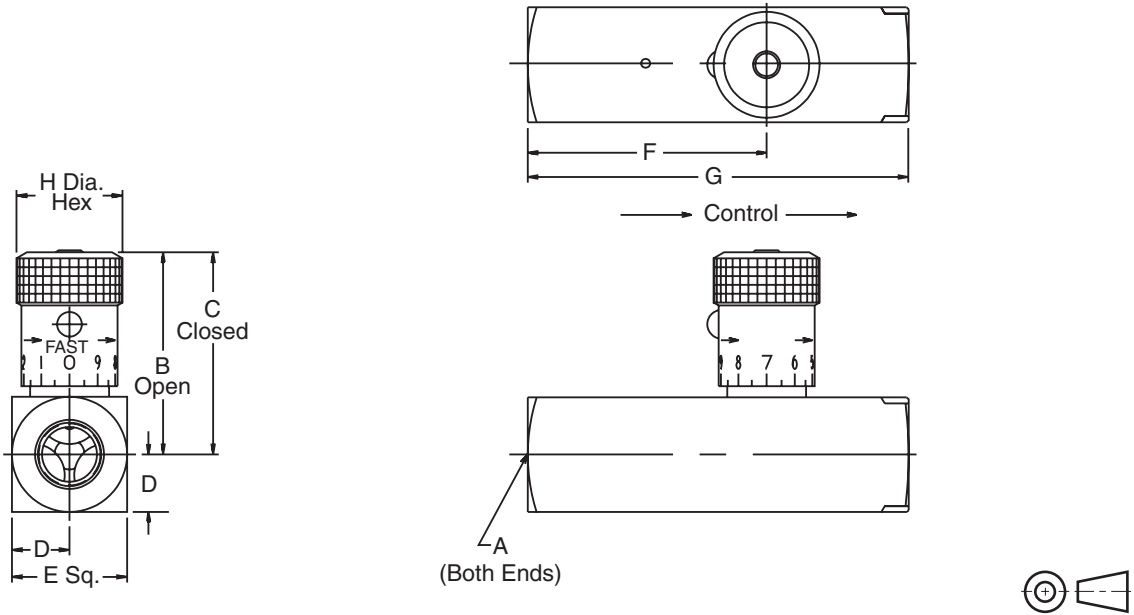

Model Number	Weight kg (lbs.)	A	B	C	D	E	F	G	H
6F616	0.3 (0.7)	M16 x 1.5	47.8 (1.88)	42.7 (1.68)	12.7 (0.50)	25.4 (1.00)	48.7 (1.92)	79.2 (3.12)	20.6 (Ø 0.81)
6F818	0.5 (1.1)	M18 x 1.5	56.9 (2.24)	51.1 (2.01)	14.2 (0.56)	28.4 (1.12)	53.8 (2.12)	88.9 (3.50)	25.4 (Ø 1.00)
6F1022	0.8 (1.8)	M22 x 1.5	68.6 (2.70)	61.5 (2.42)	15.7 (0.62)	31.8 (1.25)	65.0 (2.56)	101.6 (4.00)	30.2 (Ø 1.19)
6F1227	1.2 (2.6)	M27 x 2.0	85.9 (3.38)	71.4 (2.81)	19.1 (0.75)	38.1 (1.50)	76.5 (3.01)	117.3 (4.62)	35.1 (Ø 1.38)
6F1633	2.3 (5.1)	M33 x 2.0	124.7 (4.91)	108.0 (4.25)	22.4 (0.88)	44.5 (1.75)	81.8 (3.22)	127.0 (5.00)	47.8 (*1.88)

* = Hex